



**COPMA**

**650**

gru\_truck\_cranes



power & technology

- ▶ Scheda tecnica
- ▶ Fiche technique
- ▶ Technische Daten
- ▶ Technical features
- ▶ Ficha tecnica
- ▶ Folha de dados

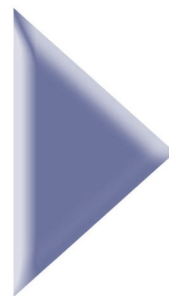

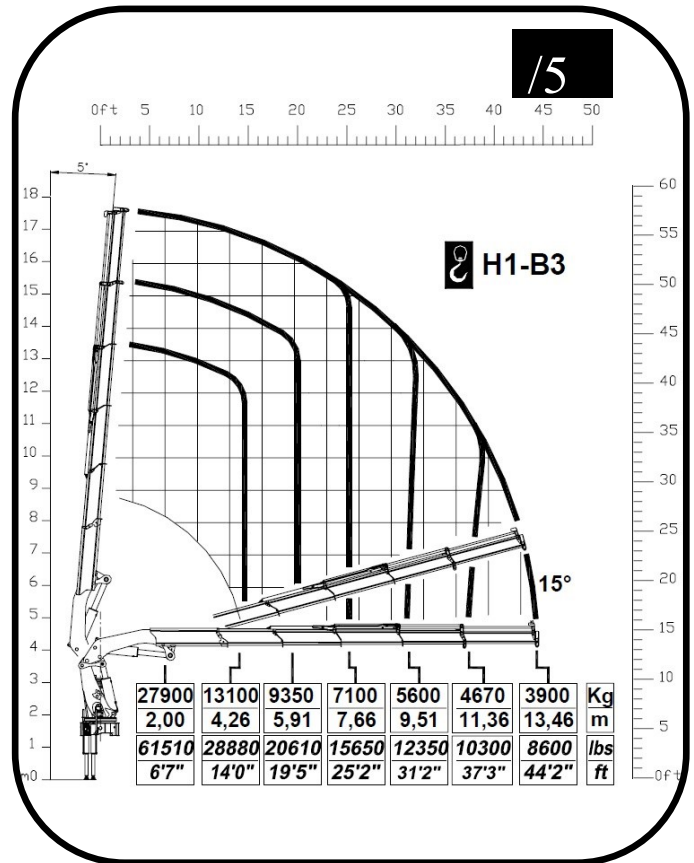
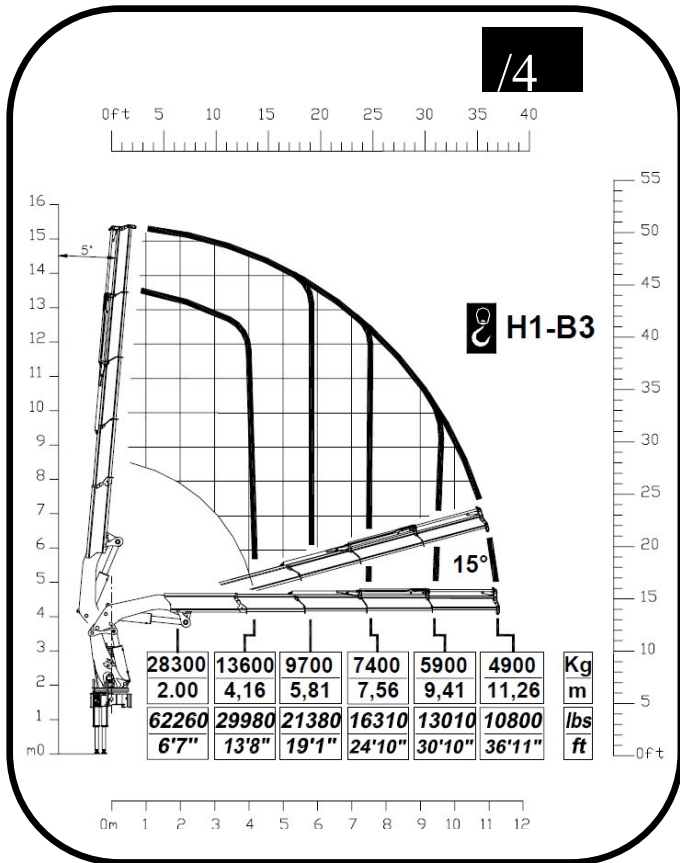

**/3**

**/4**

**/5**

**/4**

**/5**

- MOMENTO MAX SOLLEVAMENTO - HUBMOMENT - COUPLE DE LEVAGE - MOMENTO - MOMENTO - MAX LIFTING MOMENT	555 kN.m  401431 lbs.ft	548 kN.m  396368 lbs.ft	- PORTATA POMPA OTTIMALE - FÖRDERMENGE DER PUMPE - PORTÉE DE LA POMPE - CAUDAL DE LA BOMBA - CAUDAL DA BOMBA - RECOMMENDED PUMP DELIVERY	80 l/m 21,1 gal/min	80 l/m 21,1 gal/min
- ANGOLO DI ROTAZIONE - SCHWENKBEREICH - ROTATION - GIRO - ROTAÇÃO - SLEWING ANGLE	$\infty$	$\infty$	- CAPACITÀ SERBATOIO OLIO - FASSUNGSVERMÖGEN DEL ÖLBEHALTERS - CAPACITÉ RÉSERVOIR HUILE - CAPACIDAD DEL DEPOSITO DE ACEITE I - CAPACIDAD DO DEPÓSITO DE OLEO - OIL TANK CAPACITY	200 l 52,5 gal	200 l 52,5 gal
- COPPIA MAX ROTAZIONE - MAX SCHWENKMOMENT - COUPLE MAXI. DE ROTATION - POTENCIA MÁXIMA DE GIRO - BINARIO MÁXIMO DE ROTAÇÃO - SLEWING TORQUE	6400 daN.m  46291 Psi	6400 daN.m  46291 Psi	- VEICOLO MIN. P.T.T. - LKW MIN. G.G.W. - CAMION MIN. P.T.A.C. - CAMION PESO MIN. P.T.T. - P.B. MIN CAMION - TRUCK MIN. G.V.W	32 t	32 t
- PRESSIONE MAX LAVORO - DRUCK - PRESSION - PRESSIÓN - PRESSÃO - MAX WORKING PRESSURE	330 bar  4785 psi	330 bar  4785 psi	- PESO GRU - GEWICHT - POIDS - PESO - PESO - CRANE WEIGHT	5850 kg  12870 Lbs	6100 Kg  13420 Lbs

I dati e le descrizioni del presente catalogo sono forniti a titolo indicativo e non sono vincolanti. COPMA si riserva il diritto di modificarli senza preavviso. Technical features are not binding. COPMA reserves itself the right to any modification without notice.

16

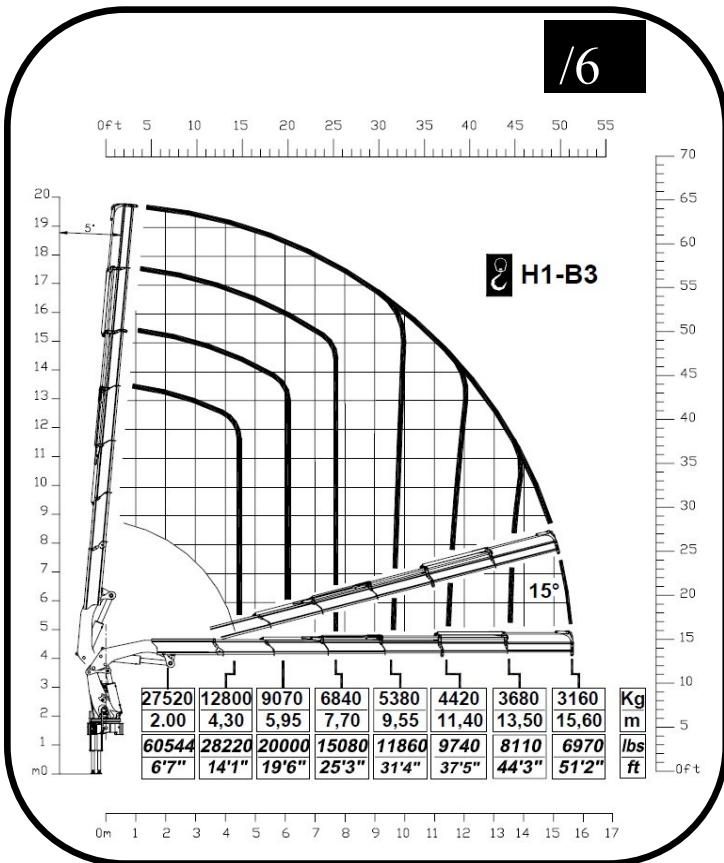

17

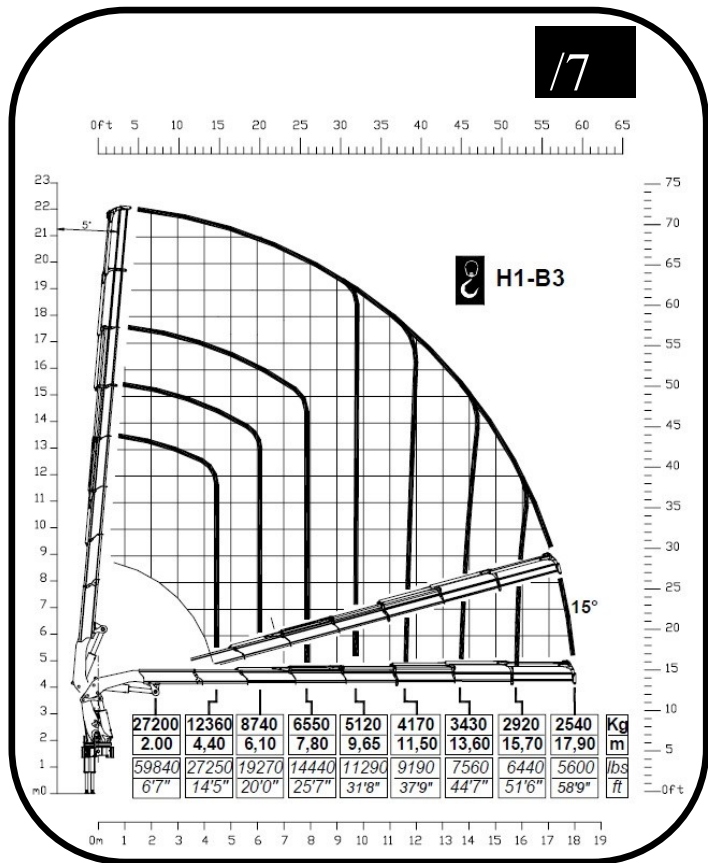

16

17

16

17

- MOMENTO MAX SOLLEVAMENTO - HUBMOMENT - COUPLE DE LEVAGE - MOMENTO - MOMENTO - MAX LIFTING MOMENT	540 kN.m  390582 lbs.ft	533 kN.m  385518 lbs.ft	- PORTATA POMPA OTTIMALE - FÖRDERMENGE DER PUMPE - PORTÉE DE LA POMPE - CAUDAL DE LA BOMBA - CAUDAL DA BOMBA - RECOMMENDED PUMP DELIVERY	80 l/m 21,1 gal/min	80 l/m 21,1 gal/min
- ANGOLO DI ROTAZIONE - SCHWENKBEREICH - ROTATION - GIRO - ROTAÇÃO - SLEWING ANGLE	∞	∞	- CAPACITÀ SERBATOIO OLIO - FASSUNGSVERMÖGEN DEL ÖLBEHALTERS - CAPACITÉ RÉSERVOIR HUILE - CAPACIDAD DEL DEPOSITO DE ACEITE I - CAPACIDAD DO DEPÓSITO DE OLEO - OIL TANK CAPACITY	200 l 52,5 gal	200 l 52,5 gal
- COPPIA MAX ROTAZIONE - MAX SCHWENKMOMENT - COUPLE MAXI. DE ROTATION - POTENCIA MÁXIMA DE GIRO - BINARIO MÁXIMO DE ROTAÇÃO - SLEWING TORQUE	6400 daN.m  46291 Psi	6400 daN.m  46291 Psi	- VEICOLO MIN. P.T.T. - LKW MIN. G.G.W. - CAMION MIN. P.T.A.C. - CAMION PESO MIN. P.T.T. - P.B. MIN CAMION - TRUCK MIN. G.V.W	32 t	32 t
- PRESSIONE MAX LAVORO - DRUCK - PRESSION - PRESSIÓN - PRESSÃO - MAX WORKING PRESSURE	330 bar  4785 psi	330 bar  4785 psi	- PESO GRU - GEWICHT - POIDS - PESO - PESO - CRANE WEIGHT	6340 kg  13948 lbs	6560 kg  14432 lbs

I dati e le descrizioni del presente catalogo sono forniti a titolo indicativo e non sono vincolanti. COPMA si riserva il diritto di modificarli senza preavviso. Technical features are not binding. COPMA reserves itself the right to any modification without notice.

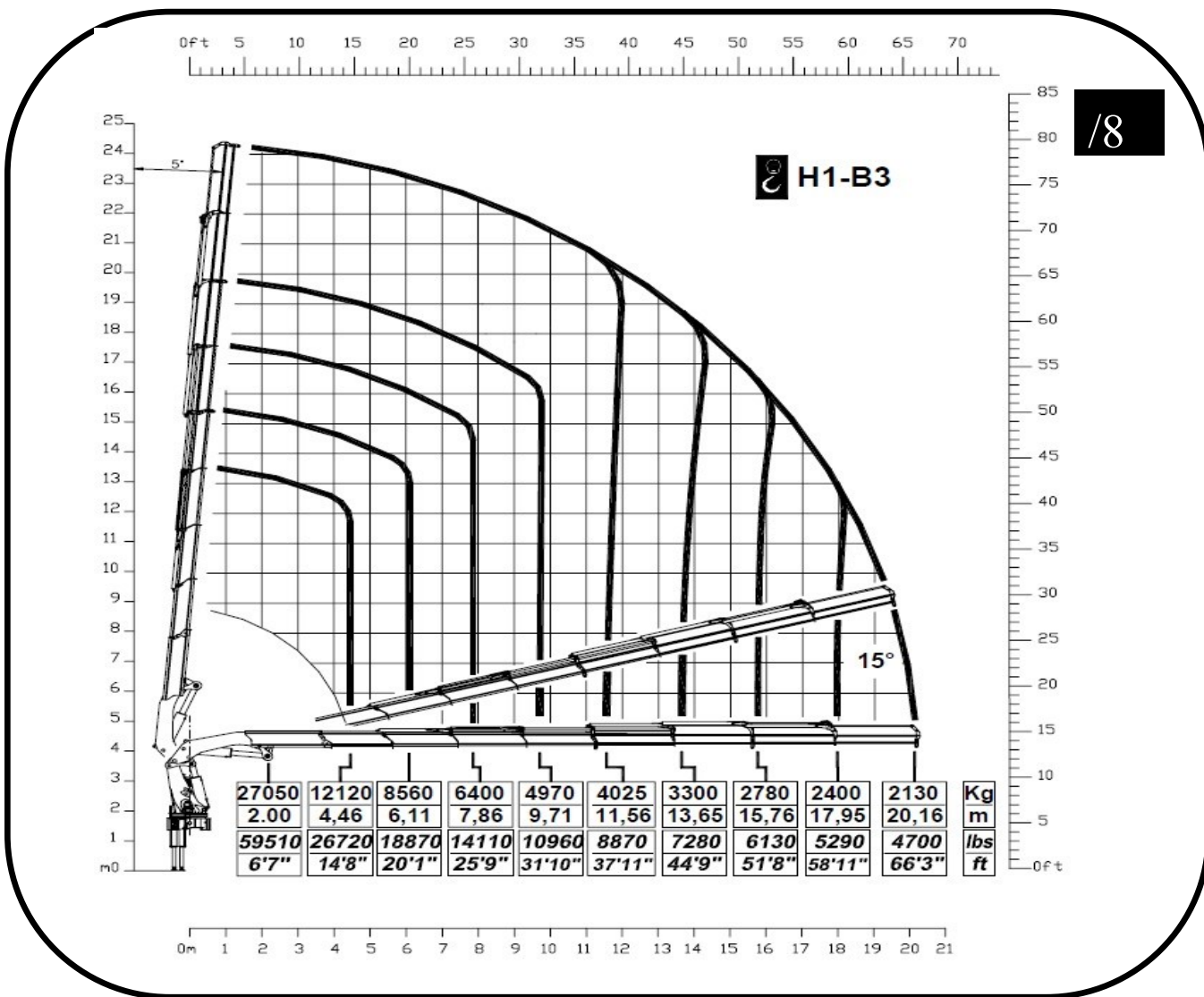

/8

/8

<ul style="list-style-type: none"> <li>- MOMENTO MAX SOLLEVAMENTO</li> <li>- HUBMOMENT</li> <li>- COUPLE DE LEVAGE</li> <li>- MOMENTO</li> <li>- MOMENTO</li> <li>- MAX LIFTING MOMENT</li> </ul>	<p>350 kN.m</p> <p>383349 lbs.ft</p>	<ul style="list-style-type: none"> <li>- PORTATA POMPA OTTIMALE</li> <li>- FÖRDERMENGE DER PUMPE</li> <li>- PORTÉE DE LA POMPE</li> <li>- CAUDAL DE LA BOMBA</li> <li>- CAUDAL DA BOMBA</li> <li>- RECOMMENDED PUMP DELIVERY</li> </ul>	<p>80 l/m</p> <p>21,1 gal/min</p>
<ul style="list-style-type: none"> <li>- ANGOLO DI ROTAZIONE</li> <li>- SCHWENKBEREICH</li> <li>- ROTATION</li> <li>- GIRO</li> <li>- ROTAÇÃO</li> <li>- SLEWING ANGLE</li> </ul>	<p>∞</p>	<ul style="list-style-type: none"> <li>- CAPACITÀ SERBATOIO OLIO</li> <li>- FASSUNGSVERMÖGEN DEL ÖLBEHALTERS</li> <li>- CAPACITÉ RÉSERVOIR HUILE</li> <li>- CAPACIDAD DEL DEPOSITO DE ACEITE I</li> <li>- CAPACIDAD DO DEPÓSITO DE OLEO</li> <li>- OIL TANK CAPACITY</li> </ul>	<p>200 l</p> <p>52,5 gal</p>
<ul style="list-style-type: none"> <li>- COPPIA MAX ROTAZIONE</li> <li>- MAX SCHWENKMOMENT</li> <li>- COUPLE MAXI. DE ROTATION</li> <li>- POTENCIA MÁXIMA DE GIRO</li> <li>- BINARIO MÁXIMO DE ROTAÇÃO</li> <li>- SLEWING TORQUE</li> </ul>	<p>6400 daN.m</p> <p>46291 Psi</p>	<ul style="list-style-type: none"> <li>- VEICOLO MIN. P.T.T.</li> <li>- LKW MIN. G.G.W.</li> <li>- CAMION MIN. P.T.A.C.</li> <li>- CAMION PESO MIN. P.T.T.</li> <li>- P.B. MIN CAMION</li> <li>- TRUCK MIN. G.V.W</li> </ul>	<p>32 t</p>
<ul style="list-style-type: none"> <li>- PRESSIONE MAX LAVORO</li> <li>- DRUCK</li> <li>- PRESSION</li> <li>- PRESSIÓN</li> <li>- PRESSÃO</li> <li>- MAX WORKING PRESSURE</li> </ul>	<p>330 bar</p> <p>4785 psi</p>	<ul style="list-style-type: none"> <li>- PESO GRU</li> <li>- GEWICHT</li> <li>- POIDS</li> <li>- PESO</li> <li>- PESO</li> <li>- CRANE WEIGHT</li> </ul>	<p>6750 kg</p> <p>14850 lbs</p>



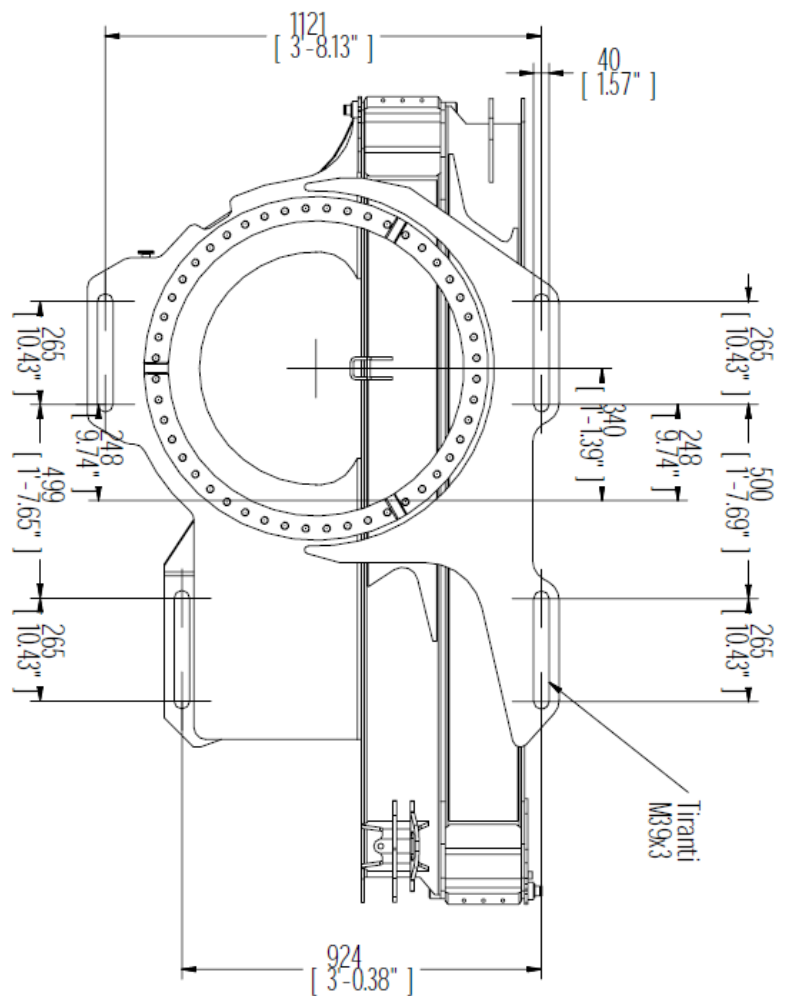
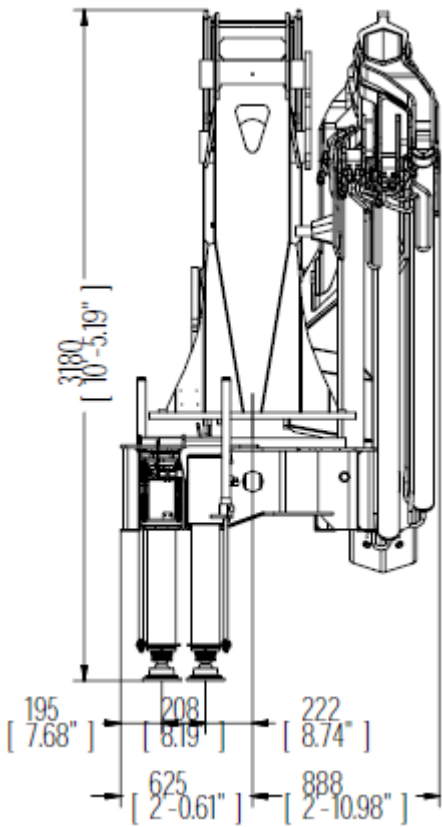
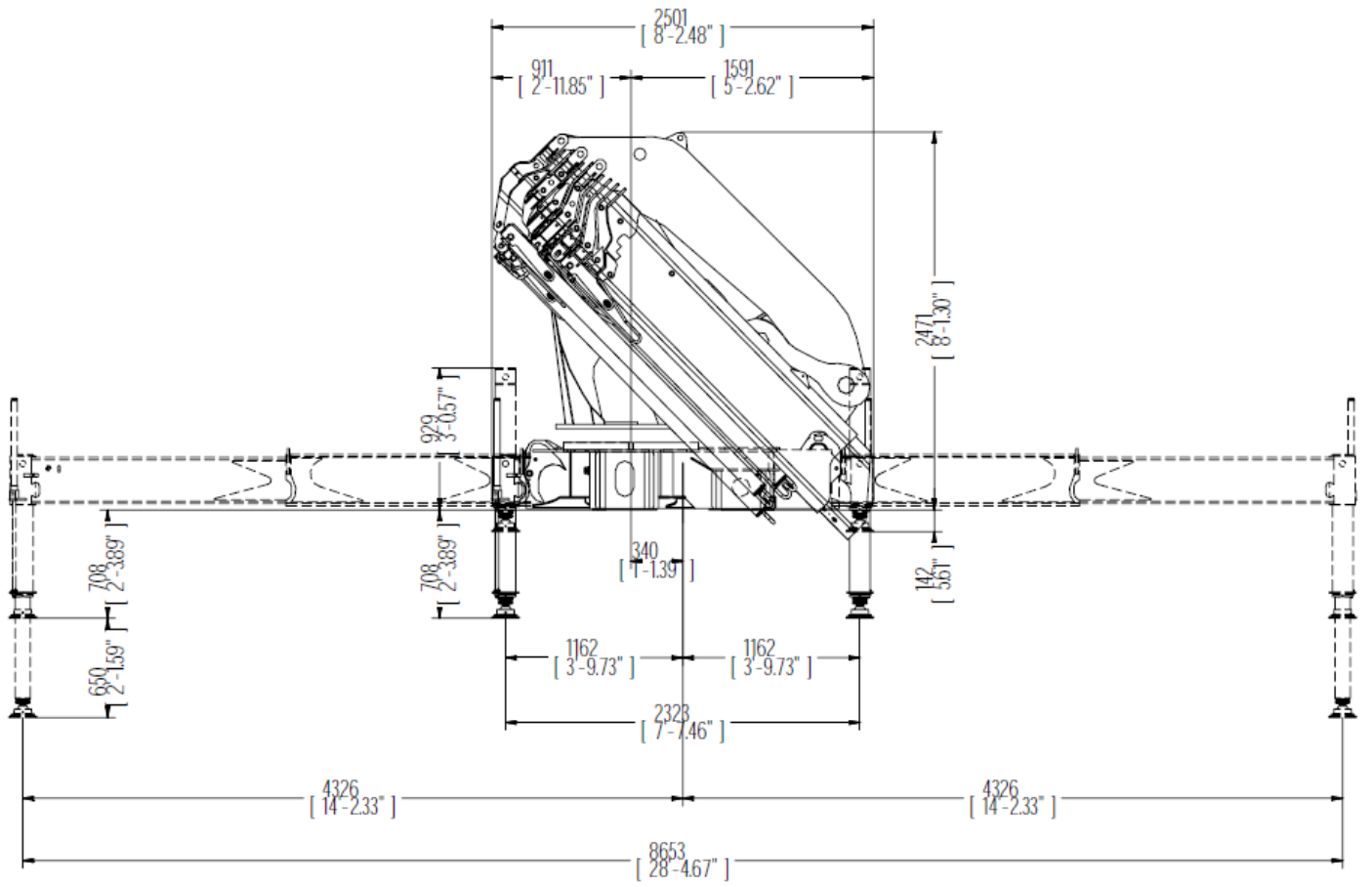

power & technology  
**gru\_truck cranes**

**www.copma-cranes.com**

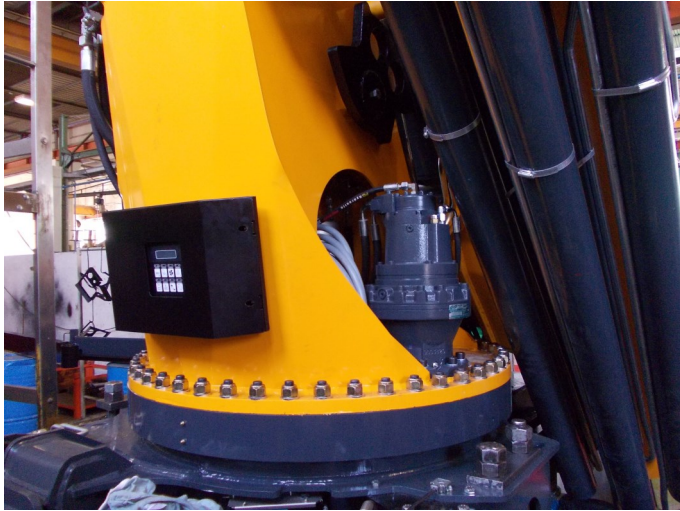

**Costruttore C.P.S. srl Via Emilia levante, 281  
48014 Castel Bolognese (RA) – ITALIA  
Tel. +39 (0)546 653833 Fax. +39 (0)546 656205  
E-Mail [info@copma-cranes.com](mailto:info@copma-cranes.com)  
[www.copma-cranes.com](http://www.copma-cranes.com)**